



DATA SHEET

Label Dispenser

Alpha Compact

Alpha Compact

Simply efficient labeling

The new Alpha Compact label dispenser now sports a new design with increased performance and higher application rates and is even simpler to operate than its tested and proven predecessors. As always, this system applies quickly and accurately pre-printed labels onto products and packaging in conjunction with various applicator units. The newly integrated controller now renders the Alpha Compact particularly space-saving and optimal to operate.

Using a conventional PC with USB interface, different-labeling parameters as well as functions like start and stop, single label feed, speed control and sensor calibration can now be entered and stored in the Alpha Compact.

Data and information backup and convenient transfer of dispenser parameters to other Alpha Compact systems is truly simple now. The changeover of labeling orders in conjunction with system controller can now become automatic.

Unsupported connections to existing system controllers are also possible and provided. Stored parameters and jobs can be called up from extensive internal data storage and can also be edited and used for different labeling jobs. A second miniature controller enables 1:1 labeling and simulates the well-known Alpha series (2 rotary and 4 push buttons) input unit, proven a thousand times over.

Special Features:

- controller integrated in the cabinet
- modular user interface (operating panel, display, PC-parameterized)
- operator menu also available in Cyrillic
- USB interface enables upload and download from the label dispenser setup
- enhanced reliability and performance
- modular system design
- rotary shaft encoder from 0 to 50 m/min (continuously variable speed adjustment)

Technical Specifications

Label Sizes

maximum 120 x 300 mm,
minimum 10 x 20 mm

Label Roll

maximum 300 mm outer diameter,
on 76 mm (3") roll core

Application Rate

up to 600 labels per minute
(depending on label size)

Maximum Application Speed

up to 50 m per minute
(depending on label size)

Application Accuracy

+/- 0.8 mm

Mechanical Construction

an enhanced coupling guarantees reliable
rewinding even with maximum label
width and speed

Label Calibration

- calibration with the push of a button
- missing labels automatically detected
- speedcontrol during operation

Connections

USB: system connected with PC,
reading and writing of parameters,
reading of status messages and error
strings; industry standard M12: product
sensor, label sensor, low label warning,
alarm light

Panel

- handy and robust HMI, aluminum
machined
- operation via two potentiometers
and 4 push buttons
- control of basic functions without
complex parameterization

Display

- access to all adjustment parameters,
- setting of exact values,
- error feedback
- multi-language user guide

Power Supply

90 ~ 264 V AC, 47 ~ 63 Hz

Power Consumption

160 W

Dimensions (h x w x d)

590 x 715 x 310 mm

Weight

from 22 kg (depending on version)

Environmental Conditions

- temperature: 10 °C to 38 °C,
- 20% to 90% relative air humidity,
- non-condensing

Certification

CE mark

Technical changes reserved at all times.

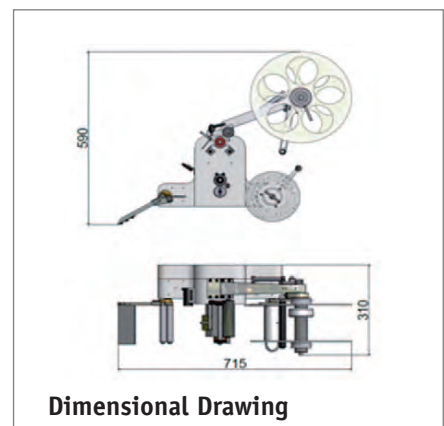

Weber Marking Systems GmbH

Head Office: Maarweg 33 · D-53619 Rheinbreitbach
Phone: +49(0)2224 7708-0 · Fax: +49(0)2224 7708-20
info@webermarking.de · www.weber-marking.com